

PRODUCT INFORMATION SHEET

Type TR60

Designed for the TR60+™ and TR80+™ profiles manufactured by SMD®.

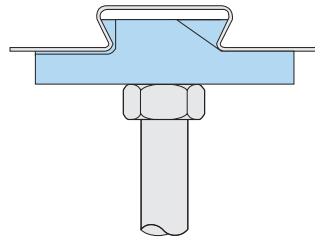
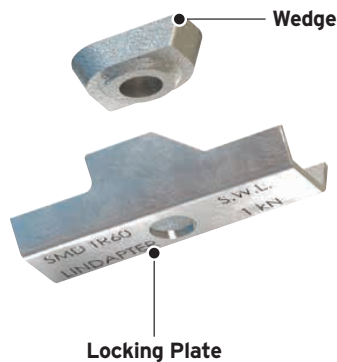
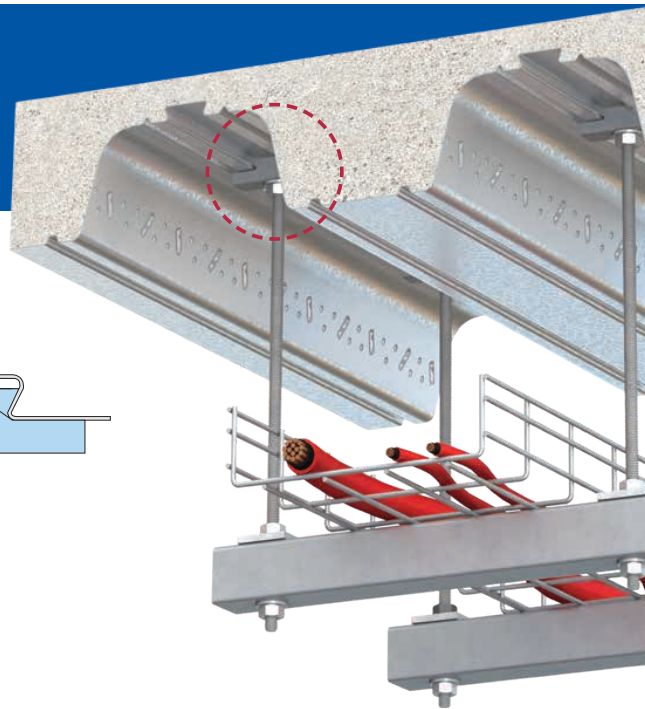

For Characteristic Resistances when designing a connection to Eurocode 3, refer to DoP No.020 (CE) or DoC No.120 (UKCA) on Lindapter's website. Alternatively, request a DoP or DoC brochure.



Locking Plate: Pre-galvanised strip. Wedge: Malleable iron, bright zinc plated.

Product Code	Rod min 4.6	Safe Working Load (FOS 3:1)	
		Tensile / 1 Rod kN	Tightening Torque Nm
TR6006*	M6	1.0	10
TR6008*	M8	1.0	10
TR6010*	M10	1.0	10

Independently fire tested in accordance with BS EN 1991-1-2. For fire ratings please refer to www.Lindapter.com

* A washer is required for TR6006. Washers are optional for TR6008 and TR6010.

How to install...

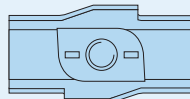

Watch the installation video at www.Lindapter.com

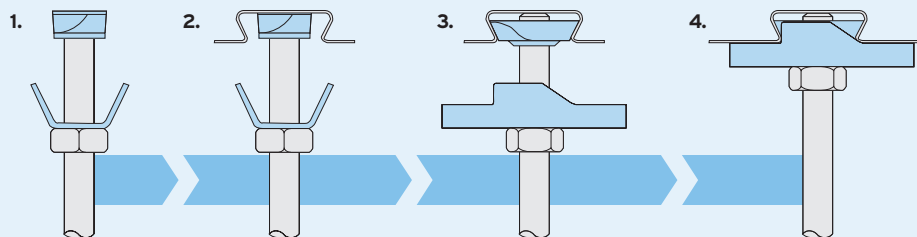

- 1) Pre-assemble the locking plate and wedge (flat surface up) onto the threaded rod.
- 2) Insert the wedge into the re-entrant channel of the decking.
- 3) Rotate until the chamfered cams engage on the sides of the channel.
- 4) Slide the plate up the threaded rod and over the wedge to lock it into position in the channel. To hold the assembly in position, tighten a nut beneath the plate and washer to the tightening torque specified in the table above.

- Install the decking fixings after the concrete has been poured and has reached full strength.
- If the decking profile is deformed or distorted, do not install the fixing. If in doubt, contact the Technical Support team for advice.

All data provided is correct at the time of print, but is subject to change by Kernow Fixings; please contact one of the Kernow team on 01726 624600 or sales@kernow-how.com to obtain the latest product information at the time of purchase.